



SERIES 30000



Surface Mounting THERMOSWITCH® Temperature Controllers

11.01.3

FEATURES

- Fully adjustable
- Overlapping ranges from 50°F to 600°F
- 1200 Watt resistive load rating at 120VAC/240VAC
- Narrow temperature differential
- UL component recognized
- CSA Certified
- Economical
- Compact size

APPLICATIONS

- Vending Machines
- Platens
- Plastic Laminating Presses
- Dental Equipment
- Popcorn Machines
- Hot Stamp
- Food Warming Trays
- Pressure Washers

DESCRIPTION

Fenwal Series 30000 Surface Mounting THERMOSWITCH® controllers operate on the principal of differential expansion of metals. A temperature increase causes the stainless steel outer case to expand at a greater rate than the internal bridge assembly. Because the case is in direct contact with the

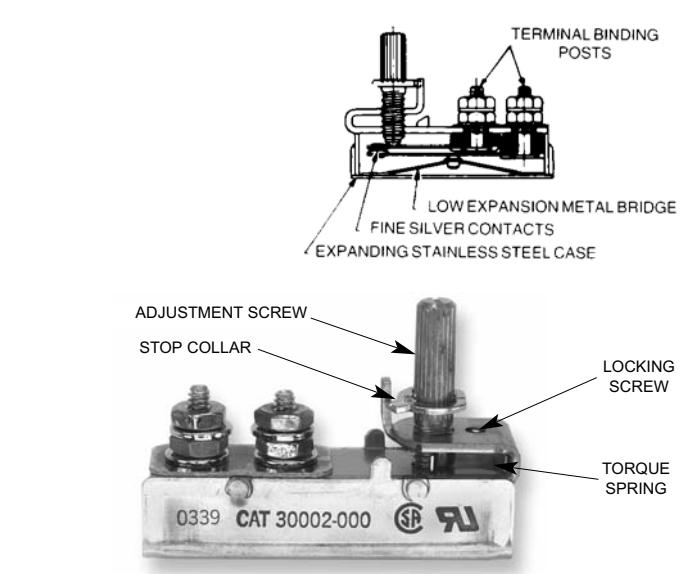

heated surface, a temperature change is sensed almost instantaneously. With an increase in temperature, the case expands. This results in a linear change of the internal bridge assembly causing the electrical contacts to open. A decrease in temperature closes the contacts.

Field tried and time tested...quality products in the Fenwal tradition.

SPECIFICATIONS

APPROXIMATE TEMPERATURE RANGE	CATALOG NUMBER	APPROXIMATE °F PER FULL TURN OF ADJUSTMENT SCREW	CONTACT OPERATION ON TEMPERATURE RISE	* MATERIAL	** CURRENT RATING	DIELECTRIC STRENGTH (Leads to Case)
50°F to 300°F	11-030000-000 4 +	250	Opens	Stainless Steel case and cover. Aluminum bronze adjusting screw. Aluminum mounting clamps.	120 VAC 10 Amps 240 VAC 5 Amps Resistive	1500 VAC 60 Hz
85°F to 250°F	11-030000-048 4 +	175				
50°F to 600°F	11-030002-000 4 +	575				

All specifications are subject to change without notice.

* In applications where contamination, corrosion or electrolysis is suspect, protect the controller so as to realize optimum performance and maximum life. Consult the factory for suggestions.

** Unless otherwise specified, all ratings apply to noninductive loads such as heaters or resistors. Tungsten filament lamps have an inrush 10 to 15 times the steady state current. Do not exceed ratings.

4 Normally available from stock.

+ Recognized under the Component Program of Underwriters Laboratories, Inc. File No. E18974

+ Certified by Canadian Standards Association File No. LR7378

Series 30000

OUTLINE DIMENSIONS

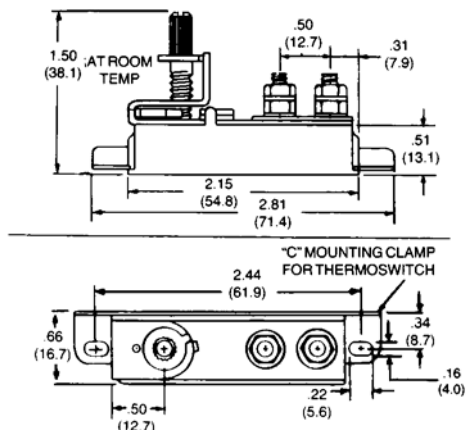

MODIFICATIONS

51 Adjusting Screw Length

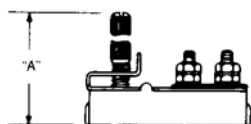

The Temperature Adjusting Screw may be ordered in different lengths so that dimensions "A" in (inches) is as follows: $1\frac{3}{64}$, $1\frac{1}{4}$, $1\frac{3}{4}$, $1\frac{7}{8}$, $2\frac{3}{8}$, $2\frac{11}{16}$. Unless this modification is specified, units will be shipped with dimension "A" $1\frac{1}{2}$

inch (38 mm) long. When ordering specify Catalog Number and Modification 51 with desired length. Typical order would read "Cat. No.30000 with Mod. 51 dimension "A", $1\frac{7}{8}$ inches long. Minimum ordering quantities apply.

52 Temperature Setting

Any unit may be factory preset within its listed range with a setting tolerance of $\pm 10^\circ\text{F}$ ($\pm 10^\circ\text{F}$ or 3% for Catalog Number 30002-0 whichever is greater).

A locking screw is furnished with this modification. (See Modification 55)

When ordering: Specify Modification 52 with temperature set at _____ °F.

53 Special Calibration

Any unit may have special high stop or low stop factory setting within its listed temperature range.

(Setting is *either* at high or low temperature setting *but not both*.)

When ordering specify high or low temperature setting.

MODEL NO.	APPROXIMATE SETTING TOLERANCE
11-030000-000	$\pm 11^\circ\text{F}$
11-030000-048	$\pm 9^\circ\text{F}$
11-030002-000	$\pm 18^\circ\text{F}$

55 Locking Screw

If units are to be temperature set by customer, a locking screw is provided with unit. Torque spring is not shipped with this unit.

55A Locking Screw and Torque Spring

If units are to be temperature set by customer, but still remain adjustable, a locking screw and torque spring are provided with unit.

62 Optional Cross Mounting Bracket

A cross mounting bracket may be added to any unit as shown.

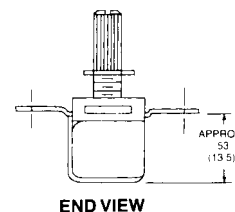
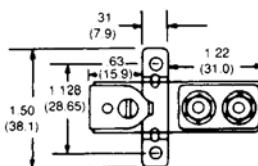

62A Same as Number 62 above except bracket is inverted.

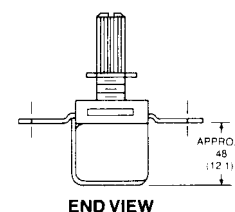

HOW TO ORDER

- Select temperature range from Specifications table. List appropriate Catalog Number
- Select required Modification from above and list Modification Numbers after controller Catalog Number.

EXAMPLE: 11-030000-048.



400 LICO Electronics GmbH, A-2320 Kledering
TEL: +43 1 706 43 000 FAX: +43 1 706 4131
office@lico.at, h.miksch@lico.at

www.mess-regeltechnik.at

These instructions do not purport to cover all the details or variations in the equipment described, nor do they provide for every possible contingency to be met in connection with installation, operation and maintenance. All specifications are subject to change without notice. Should further information be desired or should particular problems arise which are not covered sufficiently for the purchaser's purposes, the matter should be referred to LICO
© 2009 Fenwal

P/N 11.01.3 2/13/09