



Electro-Optic Liquid Level Sensors

solid-state • compact • no moving parts • minimal tank intrusion

sensing at the speed of light



Gems Electro-Optic Liquid Level Sensors... The Obvious Choice!

High Performance...At a Low Cost

ELS-Series Level Sensors are low-cost, compact electro-optic devices with built-in solid-state switching electronics. They are ideal for a wide variety of point liquid level sensing applications because our optic technology detects the presence or absence of a fluid **directly** — unlike capacitance and conductance technologies which work **indirectly** based on a fluid property that may not remain constant.

With **no moving parts**, small bodies and minimal prism intrusion, ELS-Series sensors are especially well suited for applications where high dependability and space conservation are critical requirements.



These sensors offer ±1mm repeatability and broad liquid compatibility. They are not recommended for use in any liquid that crystallizes or leaves a solid residue.

The Broadest Selection Anywhere

Gems gives you more choices in electro-optic sensors than all other manufacturers combined! Chances are that we've got the material, configuration and performance you need—right off the shelf. That means fast and affordable.



Simple Operating Principle

Gems electro-optic sensors contain an infrared LED and a light receiver. Light from the LED is directed into a prism which forms the tip of the sensor. With no liquid present, light from the LED is reflected within the prism to the receiver. When the prism is immersed in liquid, the light is refracted out into the liquid, leaving insufficient light to reach the receiver. Sensing this change, the receiver actuates electronic switching within the unit, which operates an external alarm or control circuit.

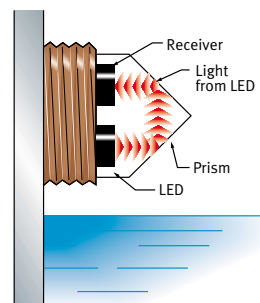

Liquid below the sensing prism.

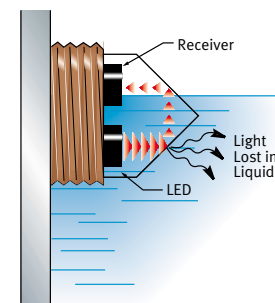

Liquid immersing the sensing prism.

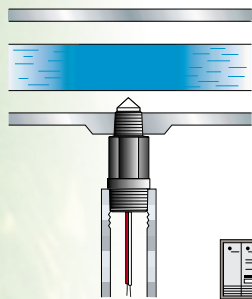

Leak Detection

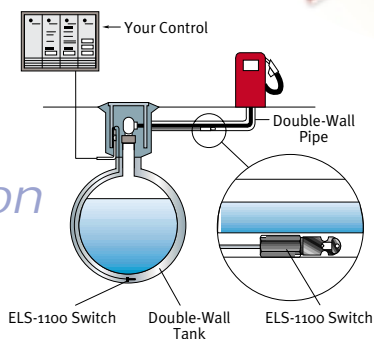

General Monitoring and Control

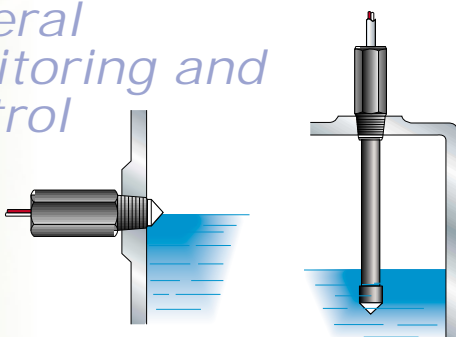

The Experience Of Gems At Your Fingertips!

Gems is the preferred fluid sensor supplier of OEMs in dozens of different industries for three very important reasons:

1. We bring innovative design, application and problem-solving approaches to meet your needs;
2. We provide unequalled, unparalleled service to our customers; and
3. We offer the most comprehensive selection of fluid sensors.

We believe that you can make a better sensor decision when you have a true choice of sensing technologies. At Gems you aren't forced to "accommodate" a sensor into your application – we have the selection to allow an ideal sensor/performance match for your specific requirements.

n
O
probl
EM

why Gems?

Gems offers technologies ranging from solid-state electro-optic and conductance level sensors to float type, electromechanical level switches... chemical vapor deposition (CVD) pressure transducers to hall-effect flow sensors. Five decades of application experience provides us with the knowledge of how to best put these technologies to work for you.

Easy Selection... Easy Ordering... Easy Delivery

Whether you contact us first or last, you'll find your sensor solutions at Gems!

Gems features an Application Center staffed with knowledgeable individuals for the sole purpose of aiding you in your search for the ideal fluid sensor. Or, visit our web site and use our online catalog of "in stock" products – with application specific search capabilities. Our online Product/Technology Library delivers a wealth of specifications to your desktop with a click of your mouse.

Please call, or visit us online, to find out why Gems is the supplier-of-choice for key OEMs around the world.



toll free
800-378-1600

www.gemssensors.com

click on "[Buy/Browse Stock Products](#)" to use our online catalog.

Gems is sensitive to today's fast-paced delivery requirements. We were the first sensor company to offer our customers the option of selecting and buying online. From Order Entry to fulfillment, we've put responsive systems in place to shorten lead times and to ensure on-time deliveries.



Call Toll Free 800.378.1600



ELS-1100 Series

Engineered Plastics for Broadest Fluid Media Compatibility

Gems ELS-1100 Series has found tremendous acceptance throughout many industries, but perhaps none so much as in medical instrumentation. Shrinking hospital and lab equipment calls for compact sensors to fit these space-critical applications. The non-metallic versions on this page accommodate this need with a sensing prism that enters a tank only a fraction of an inch. With minimal intrusion and a smooth conical prism, these sensors are also easier to keep clean.

The ELS-1100 Series integrates solid-state, TTL/CMOS compatible switching into very small polysulfone, nylon or pure Teflon® 1-piece housing. A few examples of how the medical instrument industry takes advantage of ELS-1100 electro-optic sensors:

- Sterilizers
- Body fluid analyzers
- Kidney dialysis equipment
- Blood temperature controllers

Of course general industry is also faced with demands for smaller and smarter equipment. And with the shrinking of industrial equipment, design engineers have discovered the advantages of these tiny, yet versatile, performers. ELS-1100 Series sensors are already on the job in a broad range of industrial applications where small size and high reliability are valued.

- Coolant level monitoring
- Leak detection
- Fire protection systems
- Low water pump cut-off
- Chemical bath level monitoring
- Brake and hydraulic fluid level monitoring

High Temperature — Isoplast®

ELS-1100HT/HTS handle temperatures up to 212°F.

Made from high performance Isoplast® plastic, ELS-1100HT/HTS versions are designed to take the heat! While maintaining broad chemical compatibility, these units also handle fluid temperatures to 212°F. They feature 3/8" NPT mountings and the shortest of any of our electro-optic switch bodies—HTS versions are a mere 1/2" long!



General Purpose

ELS-1100 units are both compact and economical — perfect for general applications with moderate temperature and pressure requirements.

Polysulfone or Nylon wetted parts suit most common liquids.

They feature a variety of mountings, power requirements and electrical terminations to make it easy to find a perfect match for your application.



Pure Teflon® For Pure Liquids and Aggressive Chemicals

No moving parts and Teflon® material combines for minimal particle generation.

When high purity or resistance to chemical attack is vital, ELS-1100TFE sensors are the ultimate solution.

They feature a pure Teflon® body and prism construction. Even the Hypalon® vapor barrier and Teflon® coated lead wires give evidence to the care we've taken to make this the perfect liquid level sensor for pharmaceuticals, semiconductor manufacturing, food and beverage, chemical processing, or anywhere purity or chemical resistance is the major criteria.



Flange Mounting

Ideal where threads are impossible, undesirable or cost-prohibitive.

The easy solution for thin wall tanks ($\leq 1/4$ " thick): ELS-1100FLG Series. No threads needed with these flanged units. Slip through a .75" hole and tighten the jam nut; Viton® gasket forms a tight seal. Ideal for sheet metal, molded plastic tanks and medical applications where elimination of exposed threads removes potential bacterial breeding grounds.



Dimensions General Purpose Series

1/4" NPT Mounting

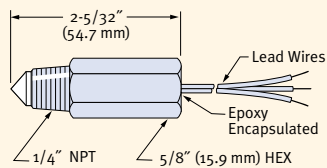

M12 x 1 Straight Thread Mounting with O-Ring

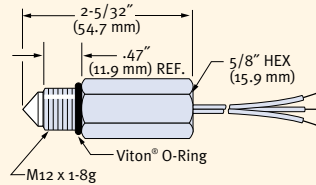

1/4" NPT Mounting with 3/8" Conduit

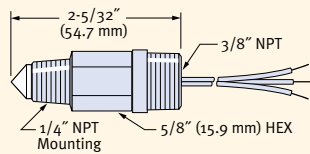

1/2" Straight Thread* Mounting with O-Ring

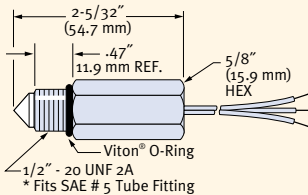

"Fish" Pull Ring (aids in leak detection installations)

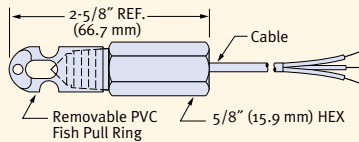

HT Series

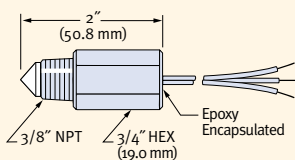

FLG Series

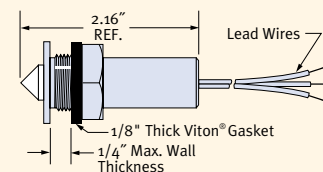

TFE Series

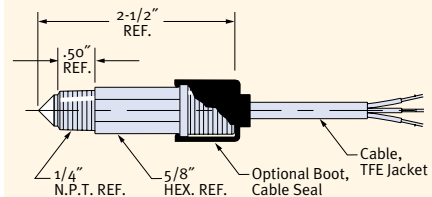

HTS Series

3/8" NPT Mounting

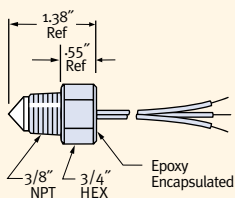

M16 x 2 Straight Thread Mounting with O-Ring

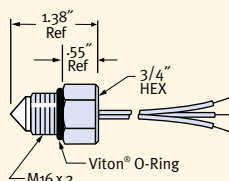

Specifications Summary

Wetted Materials	Polysulfone, Nylon, Teflon® or Isoplast®
Operating Pressure	0 to 150 PSI, Maximum
Operating Temperature*	-
ELS-1100 Series	-40°F to +176°F (-40°C to +80°C)
ELS-1100HT/HTS	-40°F to +212°F (-40°C to +100°C)
ELS-1100TFE	-40°F to +176°F (-40°C to +80°C)
Input Power	5 VDC, 12 VDC, or 10-28 VDC
Output	TTL/CMOS compatible. Open Collector Output

*These switches are not for use in freezing liquids.

For more detailed specifications, please call our Application Center.

ELS-1200 Series

Fused Glass and Steel For Pressurized Vessels to 2500 PSI

Effectively monitor high pressure liquid processes with very little intrusion into tanks or piping. ELS-1200 sensors feature glass prisms which are fused to zinc/nickel plated, carbon steel housings—a permanent, leak-proof design that eliminates problematic O-rings and compression fittings used on inferior sensors. Built to handle pressures to 2500PSI, they are the most compact, reliable and durable solution for level monitoring on HVAC&R equipment, machine tools, off-highway vehicles, and more. The glass and steel construction also provides an electro-optic solution for fluids that are incompatible with plastics, such as acetone, MEK and other aggressive solvents.

ELS-1200RE Series Features Removable Electronics Module with Conduit Connection

Some industries, such as HVAC&R, require sensors to have inherent features to help eliminate process interruptions, minimize downtime, and control replacement costs. The ELS-1200RE achieves this by incorporating a removable electronics module that is easily replaced without removing the housing from the tank. Applications in which hazardous fluids are used, environmental safety is a concern, significant cost is incurred to drain a tank, or machine uptime is critical would all benefit from the added insurance provided by ELS-1200RE sensors.

Specifications Summary

Mounting	1/2" NPT or 3/4" -16 UNJF-3A Thread
Materials	
Housing	
ELS-1200/ ELS-1200RE	Zinc/Nickel-Plated Carbon Steel
ELS-1200CR	Stainless Steel and Hastelloy®-c
Prism	Fused Glass
Operating Pressure	0 to 2500 PSI, Maximum
Operating Temperature*	
5/12 VDC (all 1200 Series)	-40°F to +212°F (-40°C to + 100°C)
24/120 VAC (ELS-1200RE)	
Prism Tip	-20°F to +240°F (-29°C to +116°C)
Electronics	-20°F to +162°F (-29°C to + 72°C)
Input Power	5 VDC, 12 VDC, 24 VAC, or 120 VAC
Output	
5/12 VDC (all 1200 Series)	TTL/CMOS Compatible. Open Collector Output
24/120 VAC (ELS-1200RE)	Switch Rating 225 mA @ Rated Voltage @ 77°F (25°C); 60 mA @ Rated Voltage @ 161°F (72°C)

* These switches are not for use in freezing liquids.
Consult factory for higher temperature units.

For more detailed specifications, please call our Application Center.

Gems™ Call Toll Free 800.378.1600

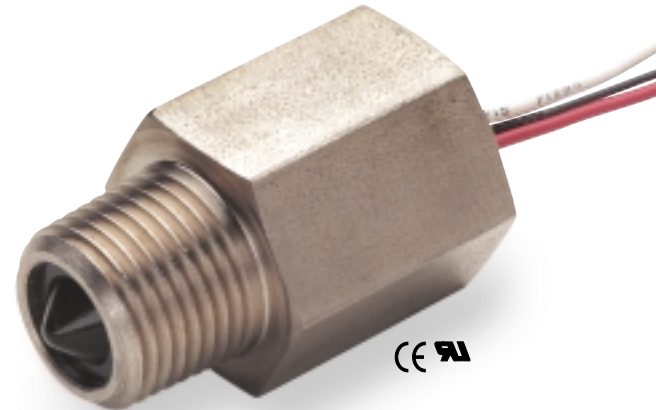

ELS-1200 Series



ELS-1200RE Series

Corrosion-Resistant ELS 1200CR

Designed for outdoor use, these corrosion resistant units are made to withstand the nastiest environments. They feature the same fused glass prism and solid-state electronics as the standard ELS-1200. A rugged body made of stainless steel and Hastelloy® delivers the ultimate corrosion protection.



Glass prism fused to Hastelloy®C tip. Stainless steel body with conduit connection.

ELS-1200 Dimensions

1/2" NPT Mounting

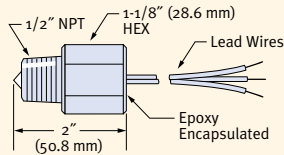

3/4"-16 Straight Thread Mounting with O-Ring

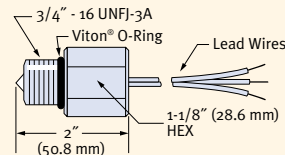

ELS-1200CR

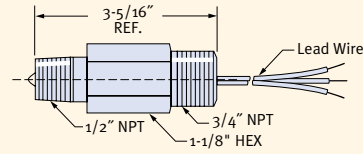

ELS-1200RE

1/2" NPT Mounting

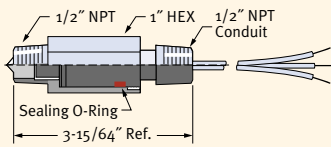

3/4"-16 Straight Thread Mounting with O-Ring

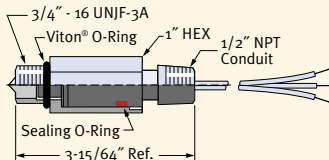

When the heat is on HVAC&R manufacturers turn to ELS-1200 Sensors

This industry has discovered the most inexpensive insurance for protecting their expensive compressors and associated systems is the Gems ELS-1200 electro-optic level sensor. By automating such things as lube oil monitoring, they are saving their customers' time and money, while eliminating human error.

Common HVAC&R Applications for the ELS-1200:

- Low compressor lube oil level warning
- Coolant level monitoring
- Refrigerant recovery equipment

ELS-300 Series

Customized Lengths Up to 15 inches

Stretch out and take a dip with the custom length ELS-300 Series. They feature the same materials and performance of our ELS-1100 Series and are suitable for general purpose use where a top or bottom mount is required. They provide the ability to detect liquid levels within 15 inches of the top or bottom on a tank.

Specifications Summary

Wetted Materials	Polysulfone
Operating Pressure	0 to 150 PSI, Maximum
Operating Temperature*	0°F to 176°F (-17.8°C to +80°C)
Input Power	5 VDC or 10-28 VDC
Output	TTL/CMOS Compatible. Open Collector Output

* These switches are not for use in freezing liquids.

For more detailed specifications, please call our Application Center.

Dimensions

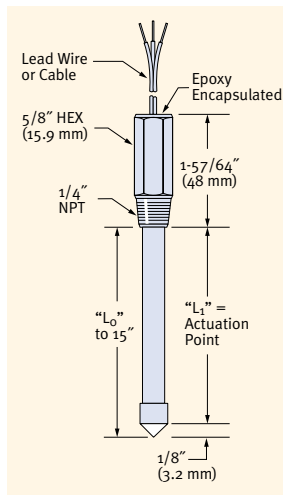

OPTO-PAK™

Controller for Gems Electro-Optic Switches

Extend power and switching capabilities of 10 to 28 VDC Electro-Optic switches

GEMS Opto-Pak Controllers convert standard 110 VAC line current to the 10-28 input power required for ELS-1100 and ELS-300 operation, and provide an SPDT, 5 Amp relay output for direct control of moderate loads. Two models are available: an open circuit board Opto-Pak Controller for incorporation into custom enclosures, and the self-contained, NEMA 4X model pictured here.

- Operates with 10-28 VDC ELS-1100, ELS-1100HT*, ELS-1200* and ELS-300 Series Electro-Optic Switches.
- Converts TTL output signal to an SPDT 5 Amp relay output.
- Available as open board or mounted in NEMA 4X junction box.

*12 VDC versions only.



Green and Red LED's indicate power and output status.

Dimensions

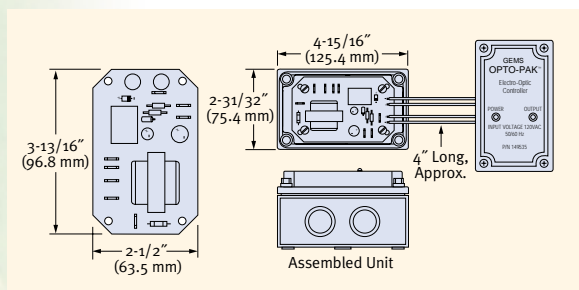

Technical Specifications

Voltage Input	115 VAC \pm 10%, 50/60 Hz
Maximum Current Draw	70mA @ 120 VAC
Relay Output	SPDT; 5 Amps @ 115 VAC, 5 Amps @ 30 VDC
Operating Temperatures	-13°F to +158°F (-25°C to +70°C)
Electrical Connections	1/4" Male Spade Terminals*

For more detailed specifications, please call our Application Center.



LICO Electronics GmbH
office@lico.at
Tel + 43 1 706 43 000
www.mess-regeltechnik.at

Specifications subject to change without notice.
The following registered trademarks are the property of their respective owners:

Teflon® – E.I. duPont de Nemours and Co.
Viton® – DuPont Dow Elastomers
Isoplast® – Dow Plastics

© 2000 Copyright Gems Sensors Inc. All rights reserved

Printed in U.S.A. 0600 10M Catalog No. 680